

CEE United

CEEs newsletter for all students – alumni and present



**Main Event:
CEE Graduation 2007**

**Interior Design
"Designs" by
Pooja, Farheen, Leena
and Sheena**

NEWSLETTER – JANUARY – JUNE 2007

January 2007 was a great start for all at CEE.

CEE students enjoyed their graduation held at Bur DUBais only 5 star hotel – the Dhow Palace Hotel.

The evening of 21st January was cool and breezy and hundreds of guests and graduating students gathered at the Dhow Palace at 5PM.

To grace the occasion, CEE invited Mr Panayot Gueigeov – MD of the Swiss Management Centre, Switzerland and Ms Anne

Andersen , Regional Advisor of Edexcel UK for the Gulf region.

The CEE Management, Administration and Faculty were all present at the event.

The evening was welcomed by the hosts for the evening – Saeed and Sakina who took charge as the MCs for the evening. The evening started with a Fashion Show organized by the students of the Fashion Department – all the clothes were designed and constructed by the students themselves and the entire evening was coordinated and choreographed by the team.

The fashion show was simply wonderful and several of the designs received a huge audience applause. Pre the show a video clipping was shown on the past several years of CEE and its participation and victory in the annual fashion awards, lots of clips of students working in the classes etc.

Outside the graduation hall, the students had placed all their constructed designs for the guests to look at.



*Constructed designs prepared by CEE students for
Bur-Juman Centre Show*



Guests of Honor



Mr Panayot Gueigeov – MD of Swiss Management Centre was the guest of honor for the event.



Ms Anne Anderson, Regional Advisor Edexcel UK

Pics of the Fashion Show at the Graduation Party

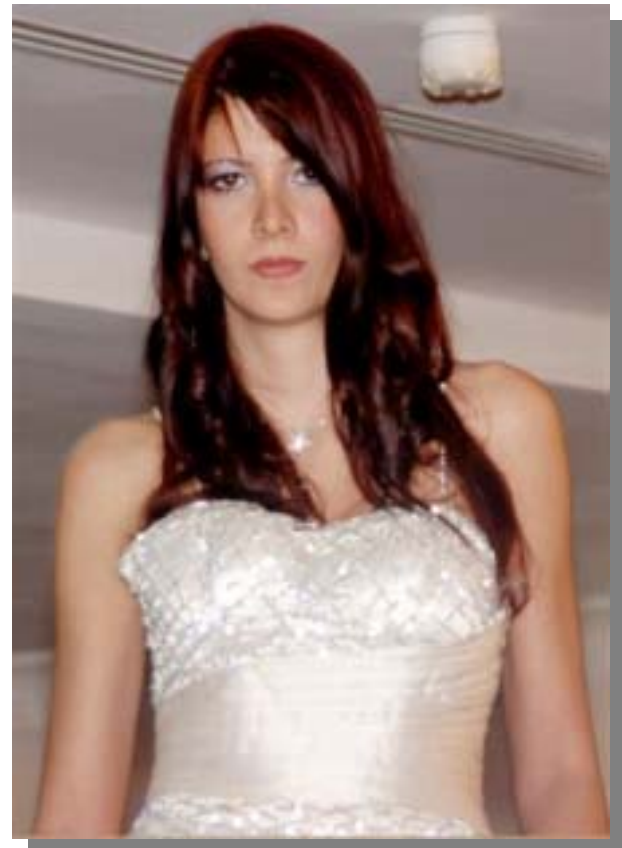



The models are CEE students and the outfits they are wearing were designed by them. The show was well choreographed. Great job fashion team!

Graduation Pics



Syed and Sakina –MCs for the Evening.



Desiree Baker (FD Diploma) with her family after receiving her diploma



Farooza (Fashion Design) with her family after receiving her diploma



Ms. Kaukab Khan after receiving the Achievement Award for her contribution to CEE by winning the Swarovski Innovation 2006 award and a position in the BurJuman awards.

Lotus Holdings Sponsored Design Awards

Lotus Holdings involved in lifestyle industry connected with CEE to offer its students an opportunity to gain exposure into designing a Coffee Shop chain and uniforms for the staff which stand out from the day to day coffee shop concept.

The response for the submissions was excellent and the students gave in their submissions for Designs for the Coffee Shops in AutoCAD and 3D drawings. The fashion team provided designs in form of sketches and swatches of outfits they deemed fit for the trendy look Lotus was seeking. At the end of it, Lotus was very impressed by the submissions made to them. They found it very hard to choose the winners as the work was of very high standards. However since they had to choose the best from the best, they finalized the following winners of the competition:

Fashion Design / Coffee Shop staff outfits

WINNERS OF THE FASHION DESIGN COMPETITION

1ST PLACE: KOK LING CHONG

2ND PLACE: MANSI GANDHI

Interior Design / Coffee Shop concept layout

WINNERS OF THE INTERIOR DESIGN COMPETITION

1ST PLACE: BERNARDINO PAZ

2ND PLACE: KASHISH SAJNANI

CONGRATULATIONS to the winners!

The 1st place winners each received a GOLDEN TROPHY and AED1000 cash prize! The 2nd place winners received a SILVER TROPHY!

Interior Design perspectives

This issue we covered perspectives from the Interior Design students to see what they are doing and how they think!

Pooja's Design – Lounge Area of a Bedroom



**A rendered perspective of the lounge area of a bedroom overlooking a busy city Street.
By Pooja**

This design was inspired by the growing urban lifestyle becoming increasingly prevalent in Dubai today. This notion is immediately depicted in the scene presented in the window. A bustling, metropolitan and fervent city is vividly visible as a view from the room. Consequently, the furniture that has been designed and used is very modern and eclectic. Most of the design is based on straight, neat lines to accentuate the modernity of the theme and design. Dark brown leather, dark oak and stainless steel form the core of the materials used within the room to represent the young, professional, city lifestyle.

Farheen's Design – Bed Room



Interior designers specialize in creating uniquely defined ambiances that cater to the spatial needs and functional requirements, using a diverse set of skills. Hidden inside a living room is the potential for calmness. Hidden inside a large corporate meeting room is the opportunity for productivity and hidden inside “a bedroom is relaxation and warmth”. I designed this bedroom putting best of my knowledge about how to utilize space in a proper and affective manner.

Its necessary to keep points like light exposure, complementary colors, and space constraints in mind while designing any space. As Interior designers we must be able to see what’s hidden inside a space to capitalize on its unique features, they must see which natural features may be emphasized or enhanced. I tried using the materials that best go with each other, making sure that they blend in nicely together and also with the colors I used. It's designed more on straight lines, with use of more horizontal lines and simple furniture with low height. The red wall was added in the room which serves as a partition and mainly for design purpose, to give it a more modern look.

Leena Jhamnani's Design – Computer Table

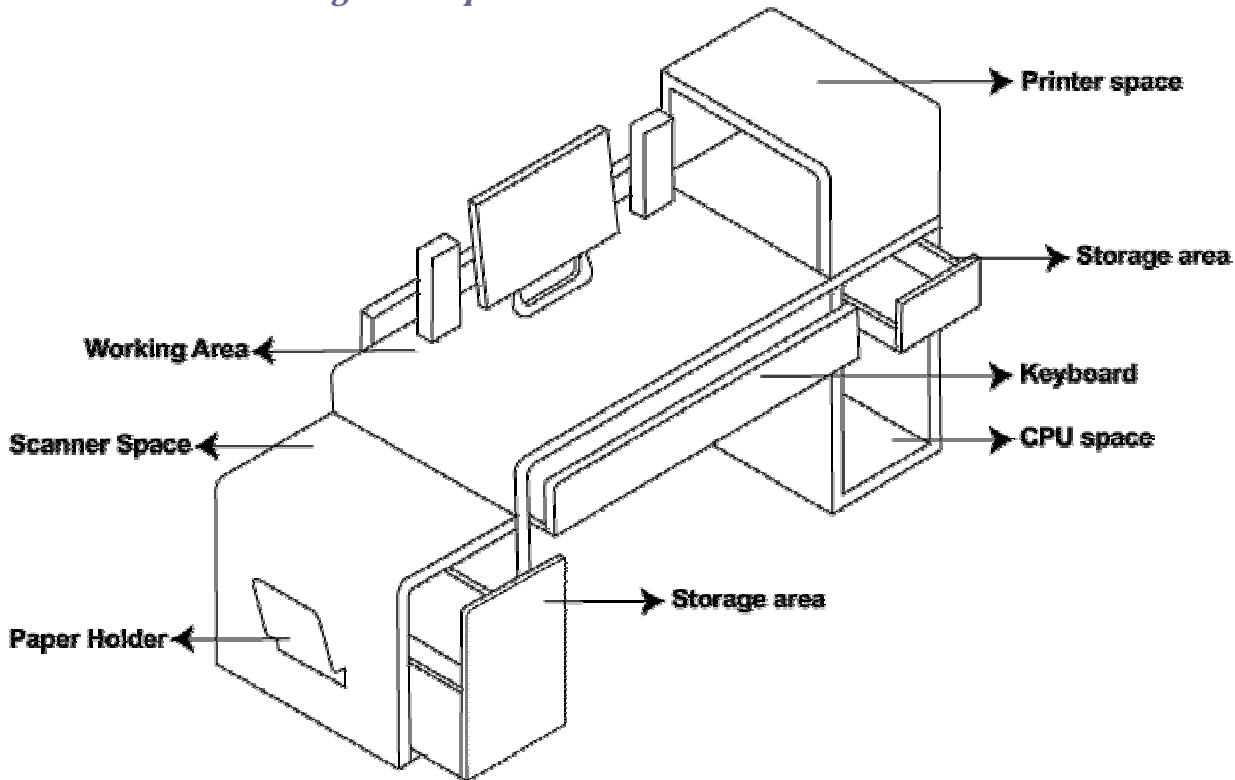

Leena says" I designed the table more like a long big workstation. The design is created keeping in mind that one doesn't have to move out of the chair many times. Every thing is within reach. There is place for every thing on the table itself like printer, scanner, stationery, and even books. There are two drawers given in the table, small is for stationary like pencil, cd, etc and the bigger one is for heavy books which a designer need to refer from time to time while working on the computer. The edges or corners of the table are slightly curved to avoid sharp edges that may hurt people. The length and width of the working space is good enough for all the requirements. The space given for the scanner is at little low height keeping in mind the opening of the cover which always goes up and the level will same as of table after keeping the machine. There is place for keyboard under the table top which can be pulled out or pushed in according to the requirement"

Sheena's Design – Perspective

According to Leonardo Da Vinci, "Perspective is nothing but seeing a place or object behind a plane of glass, quite transparent, on the surface of which the objects behind the glass are to be drawn."

The use of perspectives in drawing brings realism to the 3D representation of objects on a paper. When drawing a perspective one has to keep in mind that vertical lines and horizontal lines are not drawn with perspective, i.e. the area of the object (e.g.: rectangle, square, etc.) that faces the spectator are not drawn with perspective. It is the depth/sides of the object that gives the impression of perspective, which vanishes to the vanishing point.

There are different perspectives you can use according to the different needs:

One point perspective: We use a single vanishing point when drawing a one point perspective. It can be used to draw roads, railway tracks or room layouts.

Two point perspective: Two point perspective is drawn using two vanishing points. This is also used to draw objects and exteriors of buildings like the corners, etc.

Three point perspective: We use three vanishing points for three-point perspective.



ONE-POINT PERSPECTIVE

One point perspective is quite useful when drawing interiors especially room layouts.

When drawing a perspective there are different points that will help us to draw a picture accurately. They are:

Vanishing point: The sides of an object that is drawn vanishes to a vanishing point. The best example of this is a railway track.

Eyelevel: Eye level of the spectator who is viewing the room or object.

Ground level: The horizontal line that is drawn which acts as the base for the drawing. As the name suggests it is the ground level of the room.

Spectators point: The point where the spectator is standing to view the room or object.

When we start drawing the one point perspective of a room, we need to draw a ground level first, which is a horizontal line. Then you have to decide where the spectator stands to view the room, which is considered to be the spectators point. The point where the spectators point and his/her eyelevel meet is considered the vanishing point.

Every object in the room is then drawn with extended lines that disappear to the vanishing point. The face of the object has no perspective as most of it contains horizontal or vertical lines.

Detailing involves rendering and shading, to make objects look more realistic and also helps to convey a rough idea of the texture of the different objects in the room.

program announcements

No More Film!



Go Digital.

ed2go courses will guide you through the world of **Digital Photography!**



Click to Learn More

E-Learning programs: CEE has launched the new e-learning portal in cooperation with **ed2go** – a Thomson Education company based in the United States. The e-learning site offers **several** short term programs from all walks of life - all at or under **USD 99/-** each. The courses can be completed totally online and at the end of the course students will be awarded a certificate of completion from CEE and can print a certificate from ed2go. Those interested in taking a look or perhaps tasting a program may visit www.ed2go.com/cee - we are now accepting **credit card payment** as well online. ***Ed2go has touched its one-millionth student.***

CEE Online Group: CEE has made the membership with CEE online relatively easier with a membership box placed under the **Current Students** section of the website. Just key in your email ID and follow the steps. Students will have access to class slides, templates, assessments etc.

NewIntake!

Executive Diploma Intake

September 2007: New Intake is already underway for the September term for admission into the professional diploma in:

1. **Executive Human Resources Management,**
2. **Executive Business Management**
3. **Executive Secretary**
4. **and our most popular program the Higher National Diploma HND in Business offered by Edexcel London UK.**

Students interested in pursuing the above may contact Mr. Benny on benny@cee.ac.ae or Ms Deepali on deepali@cee.ac.ae

The calendar of offer is placed on CEE website under **Calendar Section**

New Program Announcement from September 2007

Due to high demand and positive industry response, CEE will offer 2 new diploma programs starting Sept 2007:

1. Professional Diploma in Interior Architecture – top up program of the Diploma in Interior Design. Existing students and alumni (past batches of maximum 3 years ago) are invited to participate in this unique top up Diploma starting September 2007. For more information contact the Admissions Office.

2. Professional HR Diploma in Executive Training & Development – A must program for the HR students and professionals.

Signing Off

Overall it has been a great few months of 2007. Summer is already here! We look forward to presenting our Summer Newsletter towards end of September and hope you find it cool as well!

There are several students who have asked if they can contribute to the newsletter. Yes! Of course. Email me on info@cee.ac.ae – an article, jokes, cartoons, photographs, travel memoirs etc and we will publish them (as long as they serve a group interest!)

This news just came in:

We will hold our first Student Council Elections in October 2007. The council will be empowered to make several events happen through out the calendar year.

All those students who are interested may contact Ms Deepali on deepali@cee.ac.ae

Best Wishes to all CEE students and alumni!

Kashish Batheja

Kashish Batheja
Executive Manager
Centre for Executive Education
Dubai Knowledge Village, Dubai, UAE
Tel: +9714 3900990
Email: info@cee.ac.ae

Students / Faculty:

SEND IN ARTICLES, JOKES, REAL STORIES WHATEVERRRR ... TO CEE UNITED
– YOUR NEWSLETTER

info@cee.ac.ae